

## BOUNDS FOR EIGENFREQUENCIES OF A PLATE WITH AN ELASTICALLY ATTACHED REINFORCING RIB†

DAVID W. FOX and VINCENT G. SIGILLITO

Applied Physics Laboratory, The John Hopkins University, John Hopkins Road, Laurel, MD 20810, U.S.A.

(Received 23 April 1981; in revised form 24 June 1981)

**Abstract**—We give rigorous upper and lower bounds to frequencies of vibration of a thin rectangular elastic plate with a variable length reinforcing rib bonded to it along a portion of a center line of the plate. The intent of this study is to demonstrate by a relatively simple but realistic example how the lower bound method can be used effectively for composite structures and to show that the method can be applied much more widely.

### 1. INTRODUCTION

In this article we give rigorous lower and upper bounds for the frequencies of vibration of a rectangular plate reinforced by a rib bonded to it along a portion of a center line. The lower bounds are obtained by intermediate problems[2], and the upper bounds are found by the Rayleigh–Ritz procedure. These calculations serve to demonstrate how these techniques can be utilized to compute rigorous estimates for frequencies of a considerable variety of built-up structures. We believe that our results given here are the first rigorous two-sided bounds for this kind of structure.

While it is true that Rayleigh–Ritz upper bound calculations frequently give very good eigenvalue estimates that can be further improved by extrapolation (see, e.g. [6 or 11] in which extrapolated bounds gave the exact eigenvalues), this is not always the case. In those problems in which the exact values are not *a priori* known one has no guarantee, without auxiliary information equivalent to lower bounds, that the extrapolated values are close to the exact values. In fact, in some cases the Ritz eigenvalues do not get close! An example is shown later in this article in which the upper bounds increase without limit as the beam is more rigidly attached to the plate while the lower bounds do tend toward appropriate limiting values. Thus, even though the Ritz calculations use natural mode shapes that are admissible, such vectors do not give good bounds because they cannot satisfy the geometric boundary conditions that arise in the limit.

Earlier applications of these techniques have provided good rigorous bounds for membrane [14], beam [13], and plate problems [3–5, 12]. In addition, we have shown recently [10] that they can be used effectively in a simple plate-beam structure chosen for computational ease. There the beam and the plate were taken to be simply supported, and the beam ran the full length of the plate. In contrast, the problem treated here deals with a simply supported plate reinforced with an elastically attached free beam of length less than that of the plate. The variable length in itself quite substantially changes the analysis, and the free end conditions on the beam add to the computational complexity.

While the principal purpose of this study is to demonstrate how the lower bound methods can be used to obtain rigorous estimates for the frequencies of relatively simple but realistic composite structures, the numerical results we give may be of some practical use as well. In keeping with the goal of this work, we have restricted our calculations to the estimation of the frequencies of a simple structure and to only one of the symmetry classes of mode shapes. We give quite a general discussion of how the methods we employ can be extended to far wider classes of problems.

In the next section we describe the mathematical model of the structure we have in mind

†This work was supported by the Department of the Navy, Naval Sea Command under contract No. N00024-81-C-5301. 5301.

and then in the following section give a sketch of the lower and upper bound methods. Subsequently, the results of our calculations are given along with an indication of the effect of changing the principal parameters in the bound methods. In the last section we give a discussion of the ways in which the methods used can be employed in problems related to the one studied here.

## 2. THE STRUCTURAL MODEL

### (1) *Mathematical description*

In our model of the structure (see Fig. 1) we describe the plate by classical thin plate theory and the beam by simple bending and torsion. The elastic bond between the beam and the plate is represented by a constant modulus  $K$  that gives rise to an effective force  $q$  per unit area on the plate that has a resultant force  $Q$  and a moment  $M$  (see Fig. 2). The force  $q$  is proportional to the difference between the deflection of the bottom of the rib and the top of the plate.

This model gives rise to the following coupled system of equations for the beam deflection  $v$ , the beam torsion  $\theta$ , and the plate deflection  $w$ :

$$\left. \begin{aligned} B \frac{d^4 v}{dx^4} + Q - \sigma \omega^2 v &= 0, & -e < x < e, \\ d^2 v/dx^2 = 0, d^3 v/dx^3 &= 0, & x = \pm e, \end{aligned} \right\} \quad (1)$$

$$\left. \begin{aligned} C \frac{d^2 \theta}{dx^2} + M + \tau \omega^2 \theta &= 0, & -e < x < e, \\ d\theta/dx &= 0, & x = \pm e, \end{aligned} \right\} \quad (2)$$

$$\left. \begin{aligned} D \nabla^4 w - q - \rho \omega^2 w &= 0, & -a < x < a, -b < y < b, \\ w = 0, \nabla^2 w &= 0, & x = \pm a \text{ and } y = \pm b, \end{aligned} \right\} \quad (3)$$

where

$$\left. \begin{aligned} Q(x) &= \int_{-c}^c q(x, y) dy = K \left[ \int_{-c}^c -w(x, y) dy + 2cv(x) \right], & -e < x < e, \\ M(x) &= \int_{-c}^c yq(x, y) dy = K \left[ \int_{-c}^c -w(x, y)y dy + \frac{2c^3}{3} \theta(x) \right], & -e < x < e, \\ q(x, y) &= K[v(x) + y\theta(x) - w(x, y)], & -e < x < e, -c < y < c. \end{aligned} \right\} \quad (4)$$

In the above equations,  $B$  and  $C$  are the beam flexural and torsional rigidity,  $D$  is the plate flexural rigidity,  $\rho$  is the plate mass per unit length,  $\sigma$  is the beam mass per unit length,  $\tau$  is the beam mass polar moment of inertia per unit length, and  $\omega$  is the symbol for the vibrational frequencies

Because of the physical symmetry of the rib reinforced plate shown in Fig. 1, the solutions of the system of eqns (1)–(4) belong to symmetry classes that depend on whether  $w$  is odd or even in  $y$ . If  $w$  is even in  $y$ ,  $M$  is independent of  $w$ ; and if  $w$  is odd,  $Q$  is independent of  $w$ . Thus for solutions even in  $y$  the system that governs the motion is (1), (3) and the first and third of (4), i.e. coupled beam bending and plate deflection even in  $y$ , while for odd solutions it is (2), (3) and the second and third of (4), i.e. coupled beam torsion and plate deflection odd in  $y$ . Further, there is odd-even symmetry with respect to  $x$  so that each of these symmetry classes can be decomposed into the subclass that are even or odd with respect to  $x$ . All of the computations reported here were done in the symmetry class of solutions even in  $x$  and in  $y$ .

The starting point of our lower bound calculations is the simpler uncoupled problem that results when  $K$  is put equal to zero. Then the system (1)–(3) is totally uncoupled, and the frequencies and mode shapes are obtained by solving the vibration problem for each of the pieces separately. In addition, the mode shapes of the uncoupled problem are suitable functions for the Rayleigh–Ritz problem upper bound calculations. Naturally, all of the symmetry considerations apply equally well to the uncoupled problem.

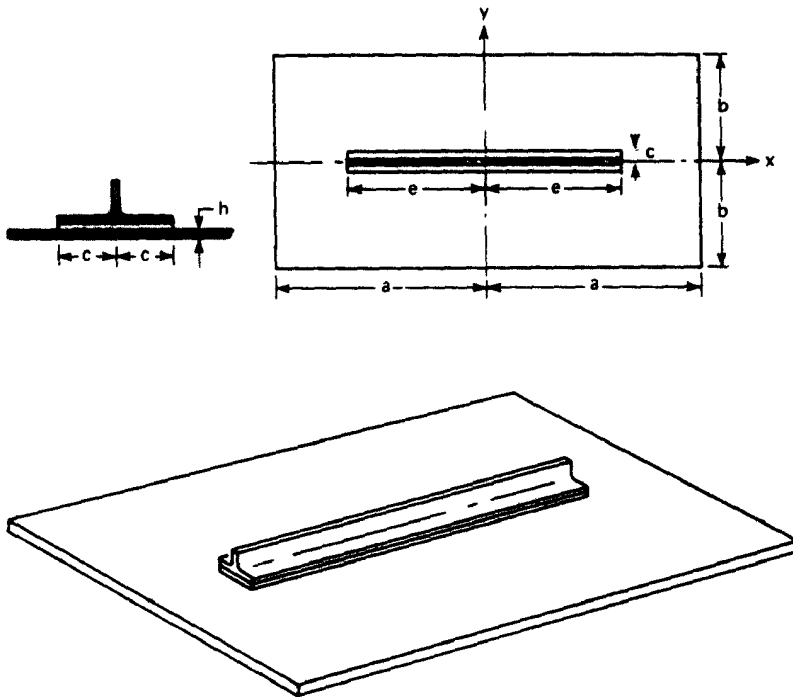

Fig. 1. Plate reinforced with rib.

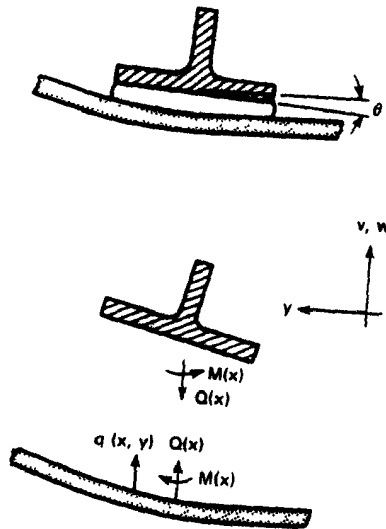

Fig. 2. Forces and moments on the plate-rib system.

Uncoupled models have been used in earlier work with good success. For instance, in [6] the analysis of the free vibrations of composite structures in terms of component modes was presented and in [7] the use of component mode analysis of nonlinear and nonconservative systems was introduced. In both of these articles a Rayleigh-Ritz analysis was used with the constraint conditions between components produced by Lagrange multipliers.

(2) *The uncoupled problem*

We give here the solutions for the even-even symmetry class in which we shall make the

computations. The beam eigenfunctions  $v_\mu^0$  are

$$v_\mu^0 = \frac{(\sigma e)^{-1/2}}{(\cosh^2 \beta_\mu + \cos^2 \beta_\mu)^{1/2}} (\cos \beta_\mu \cdot \cosh \beta_\mu x/e + \cosh \beta_\mu \cdot \cos \beta_\mu x/e)$$

$$\mu = 0, 1, 2, \dots,$$

with the eigenvalues

$$B(\beta_\mu^4/e),$$

where  $\beta_\mu$  are the nonnegative roots of the equation

$$\tan \beta + \tanh \beta = 0$$

indexed in increasing order.

The eigenfunctions  $w_{mn}^0$  of the plate are

$$w_{mn}^0(x, y) = (ab\rho)^{-1/2} \cos(2m-1)\pi x/2a \cos(2n-1)\pi y/2b,$$

$$m, n = 1, 2, \dots,$$

with the eigenvalues

$$\frac{D\pi^4}{\rho} \left\{ \left( \frac{2m-1}{2a} \right)^2 + \left( \frac{2n-1}{2b} \right)^2 \right\}.$$

The normalizing constants have been determined so that

$$\sigma \int_{-e}^e v_\mu^0(x) v_\nu^0(x) dx = \sigma_{\mu\nu}$$

and

$$\rho \int_{-a}^a \int_{-b}^b w_{mn}^0(x, y) w_{m'n'}^0(x, y) dx dy = \delta_{mm'} \delta_{nn'}.$$

### 3 THE LOWER AND UPPER BOUND METHODS

#### (1) Lower bounds

The squares of the frequencies  $\omega$  are the eigenvalues  $\lambda$  of the coupled system (1)–(4) that describes the deflections of the plate and the beam, however here it is much more convenient to consider the eigenvalues as successive stationary values of the quotient given by

$$R(u) = J(u)/\|u\|^2.$$

The quadratic from  $J(u)$ , which is twice the energy of deformation of the system, is given by

$$J(u) = B \int_{-e}^e |v''|^2 dx + D \int_{-a}^a \int_{-b}^b |\Delta w|^2 dx dy + K \int_{-e}^e \int_{-e}^e |v - w|^2 dx dy.$$

The norm  $\|\cdot\|$  of the Hilbert space  $\mathcal{H} = L^2[(-e, e); \sigma] \times L^2[(-a, a) \times (-b, b); \rho]$  in which the problem is set is stated by

$$\|u\|^2 = \sigma \int_{-e}^e |v|^2 dx + \rho \int_{-a}^a \int_{-b}^b |w|^2 dx dy.$$

function  $v$  and as its second component a plate deflection function  $w$ , which vanishes at the edges of the plate. Note that for vibrations of this system that are not even in  $y$  additional terms would enter  $J$  and  $\|\cdot\|$  to account for torsion of the beam.

The lower bound method that we use here makes use of the natural decomposition  $J = J^0 + J'$ , in which  $J^0$  is the sum of the first two terms in  $J$  and  $J'$  is the third. An important fact is that  $J^0$ , with the same boundary conditions on  $w$  as  $J$ , corresponds to a spectrally resolvable operator in  $\mathcal{H}$ , i.e. an operator for which the eigenvalues and eigenvectors are explicitly known. Indeed,  $J^0$  is just  $J$  with  $K$ , the coupling between the beam and the plate set equal to zero. The eigenfunctions are of the form  $[v_\mu, 0]$  or  $[0, w_{mn}]$ , where  $v_\mu(x)$ ,  $\mu = 0, 1, \dots$ , are the even free beam eigenfunctions and the functions  $w_{mn}$  are the simply supported plate eigenfunctions. The eigenfunctions of  $J^0$  are chosen to be orthonormal in  $\mathcal{H}$ . The second important fact is that  $J'$  is a positive quadratic form that can be bounded below by an increasing family of quadratic forms of finite rank.

The lower bound method has been described extensively in [1,2,15]. However, here we summarize briefly the essence of the procedure and refer the reader to the references for those details which we must leave out. We obtain our lower bounds by constructing a family  $J^{n,k}$  of quadratic forms that increase with  $n$  and  $k$ , that lie below  $J$ , and that correspond to operators  $A^{n,k}$  in  $\mathcal{H}$  for which we can determine the eigenvalues  $\lambda_v^{n,k}$  to any desired accuracy. These eigenvalues, which increase with  $n$  and with  $k$ , give the lower bounds

$$\lambda_v^{n,k} \leq \lambda_v, \quad v = 0, 1, \dots$$

The quadratic forms  $J^{n,k}$  require for their construction the *spectral truncation of order  $n$*  of  $J^0$  defined by

$$J^{n,0}(u) = \sum_{\nu=0}^n |\langle u, u_\nu^0 \rangle|^2 \lambda_\nu^0 + \lambda_{n+1}^0 \left[ \langle u, u \rangle - \sum_{\nu=0}^n |\langle u, u_\nu^0 \rangle|^2 \right],$$

where  $\lambda_\nu^0$  and  $u_\nu^0$  are the known eigenvalues (in increasing order) and orthonormal eigenvectors of  $J^0$ . The forms  $J^{n,0}$  are an increasing family of lower approximations of  $J^0$ . In addition, we construct a lower increasing family  $J^{n,k}$  of approximations to  $J'$  as follows: Observe that  $J'$  has the form

$$J'(u) = K \iint |v - w|^2 dx dy = \langle Tu, Tu \rangle,$$

where  $T$  is the bounded operator from  $\mathcal{H}$  to  $\mathcal{H}' = L^2[(-e, e) \times (-c, c)]$  expressed by

$$T[v, w](x, y) = K^{1/2} [v(x) - w(x, y)].$$

The approximations  $J^{n,k}$  are given in the form

$$J^{n,k}(u) = \langle P^k Tu, Tu \rangle,$$

where  $P^k$  is the orthogonal projection on span  $\{p_1, p_2, \dots, p_k\}$ , where  $p_k$  are appropriate linearly independent vectors in the domain of  $T^*$ , the adjoint of  $T$ . Here  $T^*$  is easily calculated from the defining relation  $\langle Tu, f \rangle = \langle u, T^* f \rangle \forall u \in \mathcal{H}, f \in \mathcal{H}'$ , to be

$$T^* f = K^{1/2} \left[ (1/\sigma) \int_{-c}^c f(\cdot, y) dy, -f/\rho \right],$$

where the values of  $f$  outside  $(-e, e) \times (-c, c)$  are zero.

The quadratic form  $J^{n,k}$  that gives the lower bounds is defined by

$$J^{n,k} = J^{n,0} + J^{n,k},$$

and the bounded self-adjoint operator  $A^{n,k}$  corresponding to it is

$$A^{n,k} = A^{n,0} + T^* P^k T,$$

where  $A^{n,0}u = \sum_{\nu=1}^n \langle u, u_\nu^0 \rangle \lambda_\nu^0 u_\nu^0 + \lambda_{n+1} [u - \sum_{\nu=1}^n \langle u, u_\nu^0 \rangle u_\nu^0]$ . The lower bounds are obtained from the roots of the determinantal equation

$$\det\{\langle p_\nu, p_\nu \rangle' + \langle R_\lambda T^* p_\nu, T^* p_\nu \rangle\} = 0,$$

which can be put in the matrix form

$$\det\{A/(\lambda_{n+1}^0 - \lambda) + BDB^* + C\} = 0,$$

where  $A$ ,  $B$ ,  $C$  and  $D$  are given by

$$A = (\langle T^* p_\nu, T^* p_\nu \rangle), \quad B = (\langle T^* p_\nu, u_\mu^0 \rangle),$$

$$C = (\langle p_\nu, p_\nu \rangle'), \quad D = \left( \frac{\lambda_{n+1} - \lambda_\mu^0}{(\lambda_{n+1} - \lambda)(\lambda_\mu^0 - \lambda)} \delta_{\mu\nu} \right).$$

A complete discussion of the calculation of the eigenvalues  $\lambda_\nu^{n,k}$  is given in [2].

In our applications we take the generating vectors  $p_i$  of the projection  $P^k$  to be orthogonal of the form  $v_\mu^0(x) \cdot \cos s \pi y/c$ ,  $r=0, 1, \dots$ ,  $s=0, 1, \dots$ . These form a complete system in the even-even subspace of  $\mathcal{X}$ . It should be noted that this choice of the  $p$ 's has a number of calculational advantages: The matrices  $A$  and  $C$  are diagonal, and the matrix  $B$  has a particularly simple structure. The index  $k$  is given by  $k = (\hat{r}+1)(\hat{s}+1)$  when  $r$  and  $s$  run through  $\hat{r}$  and  $\hat{s}$ , respectively. Some improvements in the bounds obtained here are possible using the recently developed methods given in [9].

## (2) Upper bound method

The Rayleigh-Ritz method, i.e. the calculation of the stationary values of  $R(u)$  in a finite dimensional space, gives an effective means for getting upper bounds. In the even-even symmetry class we have taken the spanning vectors of the Rayleigh-Ritz space to be eigenvectors  $u_\nu^0$  of  $J^0$  in this subspace. The inner products needed in the Rayleigh-Ritz calculation are elementary.

## 4. RESULTS

In this section we present a selection of the calculations that we have carried out for free beams of rectangular section bonded to the plates. These show how the eigenfrequencies change as the aspect of the plate, the length of the reinforcing beam, and the depth of the beam are changed. We also examine what happens as the modulus  $K$  of elastic attachment is varied. Another part of our results shows the way the lower bounds improve as the number  $k$  of generating functions or the index  $n$  of the truncation are increased. For comparison we give also some of our results presented elsewhere [10] for frequencies of the same plates reinforced by full length simply supported beams.

The plate side length  $a$  and thickness  $h$  have been fixed and other parameters have been varied. The aspect ratio  $a/b$  ranged from 1 to 4, and the length of the reinforcing beam ran from 1/2 to 1 times the length  $a$ . The beam was taken to be of solid rectangular cross-section of width equal to 1/40 of the plate length. The depth  $d$  of the beam was varied from 1 to 10 times the plate thickness, and the modulus  $K$  was changed over five orders of magnitude from  $10^3$  to  $10^8$ . Although we have assumed that the material properties of the beam and plate are the same, this specification is not necessary. Indeed, each of the parameters  $B$ ,  $D$ ,  $K$ ,  $\sigma$ ,  $\rho$ ,  $a$ ,  $b$ ,  $c$  and  $e$ , as well as the indices that govern the upper and lower bounds, can be specified arbitrarily in the computer programs we have used to obtain our numerical results. Material properties of the plate and of the beam were chosen to be typical of aluminum.

### (1) Variations with geometry

Tables 1-3 show the frequencies of the plate-beam system as the beam length  $2e$ , the beam depth  $d$ , and the plate width  $2b$  are varied. The plate length and thickness were held constant at 40 inches (about 1 m) and 0.10 in. (about 2.5 mm), respectively;  $K$  was kept at  $10^4$ . The beam to plate length ratio, which varied from 0.5 to 1, and the plate aspect ratio (1.0-4.0) are shown on

Table 1. Bounds for the first five eigenvalues of the coupled system with reinforcing rib length one-half of the plate length (even-even)

v	d/h	$\lambda_v \times 10^{-4}$					
		e/a = 0.50, K = 10 <sup>4</sup>					
		a/b = 4.0		a/b = 2.0		a/b = 1.0	
1	1.0	34.215	34.239	3.1915	3.1933	53349	.53374
2		80.799	80.839	22.739	22.752	13 185	13.192
3		215.70	216.07	113.08	113.31	13.743	13.752
4		557.26	557.76	175.25	175.43	43 938	43.953
5		1235.3	1240.6	269.82	269.94	89.613	89.694
1	2.0	30.018	30.042	3.0176	3.0206	.53799	.54002
2		80.120	80.204	23.945	23.973	12 791	12.801
3		227.51	229.40	122.45	123.97	14.451	14.478
4		643.45	643.83	165.00	165.23	44 193	44.230
5		1370.6	1391.4	264.27	264.48	86.862	87.026
1	5.0	22.678	22.730	2.7399	2.7599	.59346	.61773
2		108.06	108.24	39.256	39.690	11.875	11.917
3		278.45	282.55	142.84	143.84	20.155	20.605
4		899.70	923.47	159.31	161.78	51.996	53.056
5		1898.2	1908.9	271.68	271.83	81.060	81.450
1	10.0	16.155	16.237	2.2429	2.2733	.55338	.59021
2		144.52	147.16	54.123	56.835	10.754	10.825
3		547.91	550.08	127.91	128.54	23.133	24.253
4		1008.1	1031.9	199.78	201.08	58.323	63.601
5		1683.5	1695.1	353.30	358.58	76.478	77.080

each table. Lower bounds were calculated with  $\hat{r} = 4$ ,  $\hat{s} = 5$ , so that the total  $k = (\hat{r} + 1) \cdot (\hat{s} + 1)$  of vectors  $p_{rs}$  used in approximating  $J'$  was 30. The order  $n$  of the spectral truncation was taken to be 50. The Rayleigh-Ritz upper bounds were calculated using a space spanned by eighty eigenvectors of  $J^0$ . These were  $v_{\mu}$ ,  $\mu = 0, 1, \dots, 19$  and  $w_{mn}^0$ ,  $m = 1, 2, \dots, 10$ ,  $n = 1, 2, \dots, 6$ . In each column the lower bounds appear on the left and the upper bounds on the right. Thus, for example, when  $e/a = 0.75$ ,  $a/b = 2.0$  and  $d/h = 2.0$ , we give the rigorous bounds in the even-even symmetry class

$$130.24 \leq \lambda_3 \times 10^{-4} \leq 131.08.$$

The lower bounds reported in our tables were obtained by truncating to five figures the values calculated in double precision (about sixteen decimal places); the upper bounds were obtained by truncating to five figures and adding 1 to the fifth place.

For comparison we give in Table 4 the uncoupled eigenfrequencies of the same symmetry class for the plates and the full-length free beams† and in Table 5 the upper and lower bounds reported for the same plates reinforced by full-length elastically attached simply supported beams [10]. The sizes of the upper and lower bound calculation were the same as reported here.

Our first observation concerning the bounds of Tables 1-3 is that relatively modest calculations produced quite acceptable bounds for the eigenvalues.

Next, comparing Tables 1-3 with the plate eigenvalues in Table 4, it is clear that the main effect of the thinnest beams ( $d/h = 1.0$ ) is to lower the lowest frequencies due to mass loading. However as the height of the beam is increased, the influence of the free beams on the plate frequencies is highly variable, particularly for the shorter beams. This is to be contrasted with

†Note that the free beam eigenvalues  $\omega^2$  scale with  $d^2/e^4$

Table 2 Bounds for the first five eigenvalues of the coupled system with reinforcing rib length threequarters of the plate length (even-even)

$\nu$	$d/h$	$\lambda_{\nu} \times 10^{-4}$					
		$e/a = 0.75, K = 10^4$					
		$a/b = 4.0$		$a/b = 2.0$		$a/b = 1.0$	
1	1.0	33.402	33.432	3.1482	3.1504	0.53066	0.53086
2		75.103	75.254	22.111	22.183	13.157	13.166
3		211.22	211.93	112.42	112.77	13.540	13.582
4		546.76	546.87	173.19	173.41	43.209	43.257
5		1215.4	1225.6	259.55	259.87	89.056	89.145
1	2.0	28.831	28.858	2.9566	2.9596	0.54224	0.54336
2		71.902	72.570	23.738	24.130	12.669	12.680
3		234.64	236.45	130.24	131.08	14.618	14.895
4		685.00	689.72	161.88	162.17	43.215	43.528
5		1435.9	1522.9	247.04	247.85	85.901	86.055
1	5.0	21.310	21.371	2.9409	2.9799	0.78970	0.83007
2		81.216	83.447	35.940	37.154	11.667	11.733
3		556.35	567.04	141.00	141.46	20.184	20.788
4		1112.3	1206.0	213.79	214.97	48.299	49.756
5		1868.2	1879.9	254.79	261.08	79.604	79.975
1	10.0	15.487	15.677	2.7997	2.9374	0.97996	1.1343
2		157.06	157.95	80.204	80.770	10.489	10.620
3		728.38	800.21	125.59	126.28	26.200	26.448
4		1646.1	1658.8	231.67	232.65	72.129	72.982
5		1694.4	1722.4	288.78	297.65	83.176	84.941

the stiffening effect of increasing beam height which increases the eigenvalues as shown in Table 5 for elastically attached simply supported beams; this increase in eigenvalues appears also to a substantial extent for the full-length free beams as shown in Table 3. However, it is difficult to guess even the direction of the changes in frequencies for beams of intermediate length as the beam height is changed due to the compensating influences of increased beam stiffness, proportional to  $d^3$ , and increased beam mass, proportional to  $d$ .

Two other effects are to be noted in comparing Tables 3 and 5. The first is the very slight lowering of the eigenfrequencies for beams with  $d/h$  less than 10.0 when the ends of the beam are not restrained. The second is the deterioration of the accuracy of the lower bounds for deeper free beams compared with the results for the corresponding simply supported beams.

## (2) Variation with the Stiffness $K$

Tables 6 and 7 show an interesting behavior of the bounds as  $K$  is increased. The lower bounds tend toward a limiting value while the upper bounds keep getting larger. This is because the lower bounds move upward and are lower bounds for the beam rigidly attached to the plate. On the other hand, the upper bounds obtained from the vectors we have chosen cannot give good bounds for that limiting problem since they cannot satisfy the geometric boundary conditions that arise in the limit as  $K$  gets large. We regard the limiting model as somewhat unsatisfactory, for in it the beam imposes perfect rigidity against bending of the plate in the  $y$  direction along the strip of attachment where the beam becomes rigidly bonded to the plate.

The results of Table 6 were obtained by taking  $k = 30$  ( $\hat{r} = 5, \hat{s} = 5$ ) and  $n = 50$  and those of Table 7 by taking  $k = 60$  ( $\hat{r} = 10, \hat{s} = 5$ ) and  $n = 100$ . Although the lower bounds are improved in Table 7, there are no essential differences between the two sets of results.



Table 3. Bounds for the first five eigenvalues of the coupled system with reinforcing rib attached along full length of the plate (even-even)

v	d/h	$\lambda_v \times 10^{-4}$					
		e/a = 1.0, K = 10^4					
		a/b = 4.0		a/b = 2.0		a/b = 1.0	
1	1.0	33.269	33.301	3.1416	3.1437	.53036	.53046
2		73.437	73.486	22.043	22.055	13.146	13.155
3		205.30	205.64	111.99	112.18	13.579	13.585
4		530.90	533.17	172.84	173.07	43.013	43.031
5		996.91	1210.8	256.33	256.63	89.000	89.093
1	2.0	28.639	28.667	2.9507	2.9527	.54507	.54528
2		72.630	72.822	25.815	25.923	12.647	12.657
3		246.91	250.85	141.59	143.82	15.806	15.891
4		688.20	730.64	161.32	161.60	44.051	44.152
5		1263.4	1724.6	243.39	243.84	85.767	85.928
1	5.0	21.422	21.462	3.2896	3.3065	1.0119	1.0283
2		140.08	153.73	68.942	75.125	11.849	11.877
3		554.07	745.75	140.51	140.95	24.905	25.686
4		1321.9	1788.6	232.85	256.66	70.169	79.184
5		1858.9	1871.0	270.10	272.12	79.451	79.825
1	10.0	20.157	20.811	6.7492	7.3061	2.9269	3.3178
2		212.04	336.08	107.44	123.75	12.325	12.979
3		1103.6	1309.4	125.89	126.87	26.850	27.454
4		1638.7	1652.4	228.57	282.19	73.955	75.220
5		1792.6	1917.2	313.27	388.30	91.854	105.31

Table 4. Eigenvalues for the uncoupled plate and full-length beam (even-even)

v	Uncoupled Plate			Uncoupled Full-Length Beam			
	$\lambda_v \times 10^{-4}$			$\lambda_v \times 10^{-4}$			
	a/b = 4.0	a/b = 2.0	a/b = 1.0	d/h = 1.0	d/h = 2.0	d/h = 5.0	d/h = 10.0
1	39.794	3.4424	.55078	0.0000	0.0000	0.0000	0.0000
2	86.059	23.270	13.769	1.9878	7.9513	49.696	198.78
3	231.47	115.80	13.769	58.049	232.20	1451.2	5804.9
4	581.76	188.50	44.613	353.97	1415.9	8849.3	35397.
5	1295.6	278.83	93.082	1223.9	4895.8	30599.	122394.

(3) Improvement of the lower bounds

Tables 8 and 9 show the improvements that are obtained by increasing  $k$  and  $n$ . In our exploratory calculations we have found that increases in  $\hat{f}$  were of much greater effect than increases in  $\hat{s}$ , hence  $\hat{s}$  is kept fixed. The results for  $e/a = 0.75$  and  $e/a = 1.0$  are given since there is room for significant improvement for these lengths; lower bounds for  $e/a = 0.5$  are already quite good as is shown by Table 1. In general, significant improvement occurs when the

Table 5. Bounds for the first five eigenvalues of coupled system with full length simply supported reinforcing rib (even-even)

v	d/h	$\lambda_v \times 10^{-4}$					
		e/a = 1.0, K = 10 <sup>4</sup>					
		a/b = 4.0		a/b = 2.0		a/b = 1.0	
1	1.0	33.269	33.301	3.1417	3.1437	53036	53046
2		73.453	73.488	22.052	22.056	13.146	13.155
3		205.63	205.69	112.19	112.20	13.584	13.585
4		533.42	533.51	172.84	173.07	43.017	43.031
5		1212.1	1212.4	256.34	256.63	89.000	89.090
1	2.0	28.640	28.667	2.9509	2.9527	54523	54532
2		72.875	72.903	25.965	25.968	12.647	12.657
3		252.53	252.56	144.51	144.64	15.902	15.911
4		742.54	742.82	161.32	161.60	44.168	44.176
5		1769.6	1772.4	243.52	243.87	85.769	85.918
1	5.0	21.458	21.479	3.3159	3.3172	1.0336	1.0341
2		165.02	165.08	78.761	79.108	11.868	11.882
3		901.08	905.23	140.55	140.94	25.674	25.860
4		1859.1	1870.9	268.90	269.03	79.450	79.781
5		2052.9	2077.0	271.36	273.88	80.399	81.792
1	10.0	21.446	21.459	7.7713	7.7729	3.4694	3.4811
2		615.48	617.18	125.66	126.14	13.272	13.278
3		1639.8	1652.3	132.50	133.63	27.404	27.602
4		1685.4	1705.0	291.05	293.78	74.833	75.307
5		2050.1	2061.0	633.61	640.58	105.63	107.93

Table 6. Bounds for the eigenvalues of a reinforced plate. Effect of coefficient of attachment. k = 30, n = 50

v	$\lambda_v \times 10^{-4}$							
	a/b = 2.0, e/a = 0.75, d/h = 5.0, k = 30, n = 50							
	K = 10 <sup>3</sup>		K = 10 <sup>4</sup>		K = 10 <sup>6</sup>		K = 10 <sup>8</sup>	
1	2.8682	2.8759	2.9409	2.9799	2.9554	3.2060	2.9555	3.4699
2	34.209	34.406	35.940	37.154	36.307	41.315	36.311	46.329
3	136.52	136.83	141.00	141.46	141.55	158.23	141.55	188.84
4	198.35	199.47	213.79	214.97	215.29	230.20	215.30	258.88
5	225.22	226.96	254.79	261.08	260.11	281.34	260.16	308.86

truncation index  $n$  is increased; but when the gap between the lower bounds and the upper bounds is large, the influence of increasing  $k$  is important. Roughly speaking, the computing time is proportional to  $n$  and to  $k^3$  so that it is much more economical to raise  $n$  instead of  $k$ .

5 EXTENSIONS

A great variety of reinforced plates are accessible to rigorous bounds for the eigenfrequencies by the methods we have used here. We devote this short section to sketching some of the possibilities.

Table 7. Bounds for the eigenvalues of a reinforced plate Effect of coefficient of attachment,  $k = 60$ ,  $n = 100$

$\nu$	$\lambda_{\nu} \times 10^{-4}$							
	$a/b = 2.0, e/a = 0.75, d/h = 5.0, k = 60, n = 100$							
	$K = 10^3$		$K = 10^4$		$K = 10^6$		$K = 10^8$	
1	2.8745	2.8759	2.9707	2.9799	3.0107	3.2060	3.0115	3.4699
2	34.375	34.406	36.876	37.154	38.034	41.315	38.054	46.329
3	136.73	136.83	141.30	141.46	142.35	158.23	142.38	188.84
4	199.16	199.47	214.64	214.97	216.66	230.20	216.70	258.88
5	226.51	226.96	259.46	261.08	267.26	281.34	267.36	308.86

Table 8 Bounds for the first five eigenvalues of a coupled system with reinforcing rib length three-quarters of the plate length. Effect of increasing  $k$  and  $n$

$\nu$	$d/h$	$\lambda_{\nu} \times 10^{-4}$				
		$a/b = 2.0, e/a = 0.75, K = 10^4$				
		$\hat{r} = 4, \hat{s} = 5, k = 30, n = 50$	$\hat{r} = 4, \hat{s} = 5, k = 30, n = 100$	$\hat{r} = 9, \hat{s} = 5, k = 60, n = 50$	$\hat{r} = 9, \hat{s} = 5, k = 60, n = 100$	Upper Bounds
1	1.0	3.1482	3.1493	3.1483	3.1495	3.1504
2		22.111	22.114	22.159	22.170	22.183
3		112.42	112.43	112.65	112.70	112.77
4		173.19	173.32	173.19	173.32	173.41
5		259.55	259.70	259.60	259.76	259.87
1	2.0	2.9566	2.9577	2.9572	2.9586	2.9596
2		23.738	23.780	23.939	24.056	24.130
3		130.24	130.31	130.70	130.91	131.08
4		161.88	162.06	161.89	162.06	162.17
5		247.04	247.34	247.26	247.65	247.85
1	5.0	2.9409	2.9489	2.9552	2.9707	2.9799
2		35.940	36.118	36.445	36.876	37.154
3		141.00	141.28	141.02	141.30	141.46
4		213.79	214.47	213.92	214.64	214.97
5		254.79	257.52	255.91	259.46	261.08
1	10.0	2.7997	2.8268	2.8492	2.9040	2.9374
2		80.204	80.511	80.289	80.614	80.770
3		125.59	126.00	125.62	126.06	126.28
4		231.67	232.34	231.70	232.36	232.65
5		288.78	292.29	290.65	295.39	297.65

The problems we have studied in this article can be modified in a large number of ways: The material properties of the beam and of the plate can be different, and the beam need not be rectangular so that its stiffness  $B$ , its mass per unit length  $\sigma$ , and the width  $2c$  of the elastic attachment can all be chosen independently. Further, the beam need not be attached along the center line, although this eliminates the  $y$ -symmetry and causes the bending of the plate to be coupled with torsion as well as bending of the beam. In addition, the beam need not be

Table 9 Bounds for the first five eigenvalues of coupled system with reinforcing rib attached along full length of plate Effect of increasing  $k$  and  $n$ 

$\nu$	$d/h$	$\lambda_{\nu} \times 10^{-4}$				
		$a/b = 2.0, e/a = 1.0, K = 10^4$				
		$\hat{r} = 4,$ $\hat{s} = 5,$ $k = 30,$ $n = 50$	$\hat{r} = 4,$ $\hat{s} = 5,$ $k = 30,$ $n = 100$	$\hat{r} = 9,$ $\hat{s} = 5,$ $k = 60,$ $n = 50$	$\hat{r} = 9,$ $\hat{s} = 5,$ $k = 60,$ $n = 100$	Upper Bounds
1	1.0	3 1416	3 1427	3 1416	3 1428	3 1437
2		22.043	22 045	22 050	22 052	22 055
3		111.99	112 00	112.13	112.15	112 18
4		172 84	172 98	172 84	172.98	173 07
5		256 33	256.52	256.33	256 52	256 63
1	2.0	2.9507	2 9517	2 9508	2 9518	2.9527
2		25.815	25 830	25.880	25.907	25.923
3		141.59	141 92	142 95	143 52	143 82
4		161 32	161 49	161 32	161 49	161 60
5		243 39	243 64	243 44	243 70	243 84
1	5.0	3 2896	3 2933	3.2969	3.3030	3 3065
2		68 942	70 198	71 764	73 983	75 125
3		140 51	140 80	140.51	140.81	140.95
4		232.85	236 93	244.78	252 66	256 66
5		270 10	271 31	270.16	271 51	272 12
1	10.0	6.7492	6.8441	7 0079	7 1935	7.3061
2		107 44	110 56	115 57	120 96	123 75
3		125 89	126 24	125 94	126 42	126 87
4		228.57	235 70	257 67	274 65	282 19
5		313.27	317 18	329 80	358 38	388 30

symmetric in  $x$ . Further, one or more reinforcing beams not necessarily parallel to the edges of the plate can be treated by relatively small modifications of the technique we have used here; for instance, diagonal ribs are quite feasible.

Other extensions to reinforcements by beams of nonuniform sections or nonuniform elastic bonds can be handled by recourse to some of the procedures given in [2]. By employing some of these ideas it should be possible to rigorously estimate the frequencies of plate-beam models that approximate reinforcements attached by spot welding. As long as the plate is uniform, rectangular, and simply supported on two opposite edges, its nonreinforced eigenfrequencies and mode shapes can be calculated. This means that the method we have given here can be used for such boundary conditions with little change. However, if the plate is not uniform or has other edge conditions, some modifications along the lines given in [3-5, or 8] may be needed to find the lower bounds. In another direction, structures composed of several plates in the same plane bonded to each other and to reinforcing ribs can also be treated by evident extensions of the methods we have discussed here.

## REFERENCES

- 1 N. W. Bazley and D. W. Fox, Lower bounds to eigenvalues using operator decompositions of the form  $B^*B$ . *Arch. Rat. Mech. Anal.* **10**, 352 (1962).
- 2 N. W. Bazley and D. W. Fox, Methods for lower bounds to frequencies of continuous elastic systems. *J. Appl. Math. Phys.* **17**, 1 (1966)
- 3 N. W. Bazley, D. W. Fox and J. T. Stadter, Upper and lower bounds for the frequencies of rectangular clamped plates. *Zeit. Ang. Math. Mech.* **47**, 191 (1967)

4. N. W. Bazley, D. W. Fox and J. T. Stadter, Upper and lower bounds for the frequencies of rectangular cantilever plates. *Zeit. Ang. Math. Mech.* **47**, 251 (1967).
5. N. W. Bazley, D. W. Fox and J. T. Stadter, Upper and lower bounds for the frequencies of rectangular free plates. *J. Appl. Math. Phys.* **18**, 445 (1967).
6. E. H. Dowell, Free vibrations of an arbitrary structure in terms of component modes. *ASME J. Appl. Mech.* **39**, 727 (1972).
7. E. H. Dowell, Component mode analysis of nonlinear and nonconservative systems. *ASME J. Appl. Mech.* **47**, 172 (1980).
8. D. W. Fox, Lower bounds for eigenvalues of thin skew plates. *Developments in Mechanics: Proc. Sixteenth Midwest. Mech. Conf.* **10**, 127 (1979).
9. D. W. Fox, Useful technical devices in intermediate problems. *Proc. the Numerische Behandlung von Rand- und Eigenwertaufgaben mit partiellen Differentialgleichungen* (Edited by J. Albrecht and L. Collatz), pp. 36–44. Birkhäuser Verlag, Basle (1981).
10. D. W. Fox and V. G. Sigillito, Bounds for frequencies of rib reinforced plates. *J. Sound Vib.* **69**, 497 (1980).
11. L. R. Klein, Vibrations of constrained plates by a Rayleigh-Ritz method using Lagrange multipliers. *Quart. J. Mech. Appl. Math.* **30**, 51 (1977).
12. R. D. Marangoni, L. M. Cook and N. Basavanthally, Upper and lower bounds to the natural frequencies of vibration of clamped rectangular orthotropic plates. *Int. J. Solids Structures* **14**, 611 (1978).
13. N. Rubenstein and J. T. Stadter, Bounds to bending frequencies of a rotating beam. *J. Franklin Instit.* **294**, 217 (1972).
14. J. T. Stadter, Bounds to eigenvalues of rhombical membranes. *SIAM J. Appl. Math.* **14**, 324 (1966)
15. A. Weinstein and W. Stenger, *Methods of Intermediate Problems for Eigenvalues*. Academic Press, New York (1972).